



CAST Co., Ltd. www.kkcast.co.jp



The background is a dark blue gradient with a series of thin, curved lines that create a sense of motion and depth, particularly on the left side where they appear to radiate from a point.

POWER BLADE

POWER BLADE

- ① Strong
- ② Powerful press
- ③ Durable
- ④ 2 size lineup



BLADE FOR 5 TON FORKLIFT

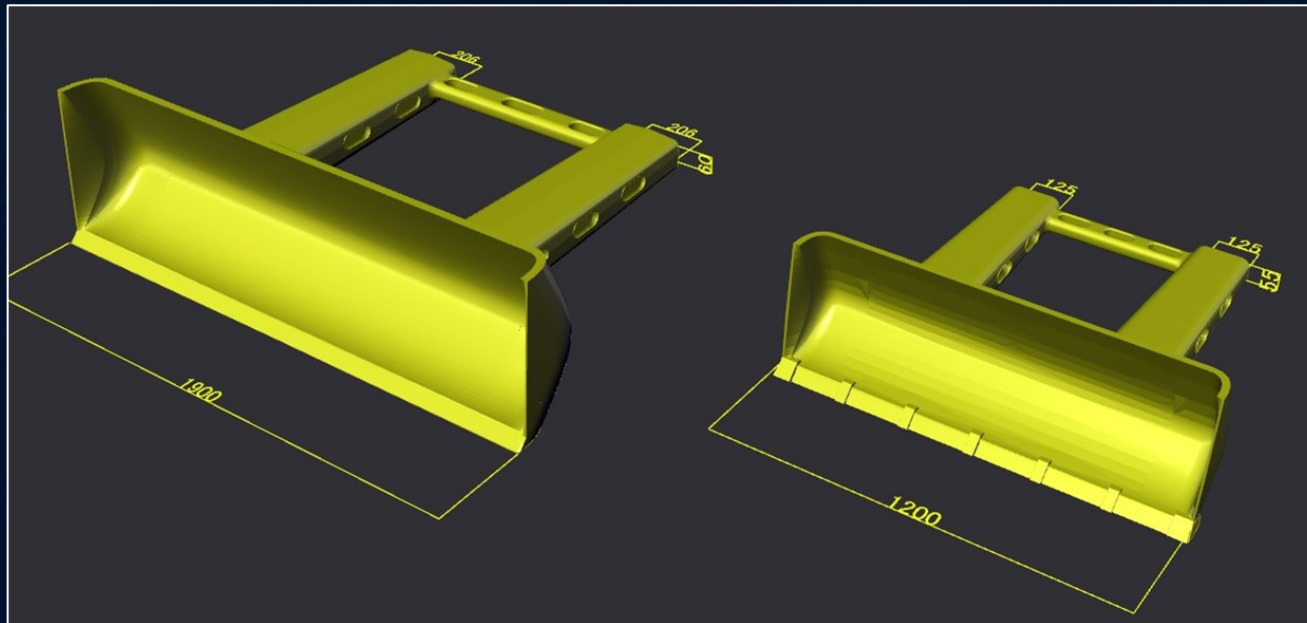

BLADES FOR FORKLIFTS UP TO 2.5 TONS
WITH SPARE ATTACHMENT

Just attach it to a forklift vehicle to make it a snow removal dozer !

Many snow removal vehicles are used to remove snow in deep snow areas. However, although the number of snowfall days per year is small, there are many places where once it snows. In such places, it is rare to have a vehicle dedicated to snow removal, and it is often the case that an attachment is attached to the tip of a forklift that is used daily for snow removal. This is especially true for small and medium-sized factories.

Other companies' products are manufactured by the method of cutting plate-shaped iron material and performing argon welding. This welded product has low strength and lacks durability, so it will bend and become unusable after a while. In addition, because the weight of the welded product is light, it is not easy to use, such as not being able to remove snow sufficiently and having to remove snow from the same area many times.

Since our power blade has an integrated structure made of cast products, it has high strength and can be used for rubble, materials, soil, etc. other than snow. We have developed a new product as a casting product by using the casting technology and CAD technology that we have cultivated over many years.

Difference from similar products

Other companies' products



About 50kg



Other companies' products

- ① Weak strength
- ② Since the weight is light, it takes time and effort many times.
- ③ Cannot be mass-produced.

POWER BLADE is

- ① Strong
- ② Can be pushed powerfully with 320 kg
- ③ Since it is a cast product, it can be mass-produced.



EMT
320kg



Curved structure

A curved structure is required for shoveling snow. It is necessary to push out the snow smoothly and powerfully. A good example is a snowplow. If you want to make a product with high strength and curved structure, casting products are more suitable than can manufacturing products. Our castings have many hollow and complex shapes, and we are also good at curved structures. In order to mold a beautiful curved structure with castings, CAD technology, casting plan technology, and technology to control the flow of hot water are required. It is determined by the evolution of CAD software, the introduction of various software such as flow analysis and hot water flow simulation, and the improvement and experience of CAD operators who master it. We have the technical know-how that we can make because we always handle the following casting points.

This curved surface shape is smooth, powerful, and pushes out snow.



Snow flow



EMT
Snow flow

Blades for forklifts up to 2.5 tons With spare attachment





PRIVACY PROTECTED

BLADES FOR FORKLIFTS UP TO 2.5 TONS WITH SPARE ATTACHMENT

installation method



① Stick a fork nail



② Pass the lashing belt



③ Fixed with ratchet

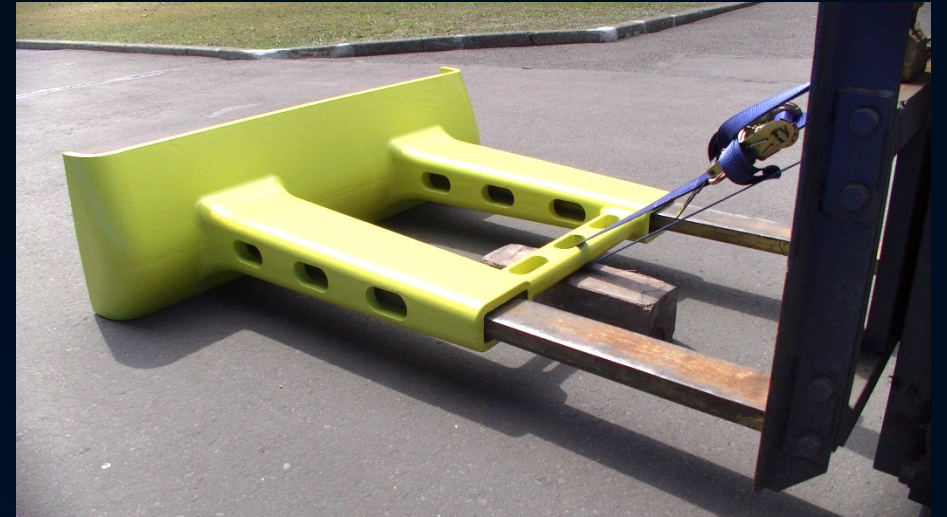

④ Installation completed



Company Profile

Company Profile



Name of Company	CAST Co., Ltd.
Representative Director	Makoto Wakabayashi
Foundation	March 1889
URL	http://www.kkcast.co.jp/
Headquarters	27F Tokyo-sankei Bldg,1-7-2 Ote-machi,Chiyoda-ku, Tokyo 100-0004
Shirakawa factory	2 Sasakubo, Higashikaminodejima, Shirakawa-shi, Fukushima 961-0302
Phone number	TEL 0248-34-3971 FAX 0248-34-3973
Factory site	Total area: 42,846 m ² Factory building: 3,960 m ² Office and others: 401m ²
Capital	35,000,000 yen
Number of employees	45 employees
Description of business	Manufacturing and sales of normal cast iron, ductile cast iron, special cast iron, super high tensile strength cast iron, etc.

Our characteristics



- 【1】 Clean foundry
Block dust generation work place.
- 【2】 Design specifications of mass production factory
Semi-automatic line simple layout.
- 【3】 Flexible manufacturing capacity.

Our proprietary technology



Image created by our company's casting as actual machine

The smooth casted surface
Since the casting of industrial robot manufactured by our company used as the body without any covering. unlike the case where the cover is attached on the outside with the inner casting parts of machine tools and industrial products, the robot manufacturer use casted parts without any cover. Robot users can see casted body and arms directly. Our technology on fine casting achieved smooth surface of casting by special casting method and process. We have condensed our know-how on manufacturing such specialized casting products for many years.

Our castings

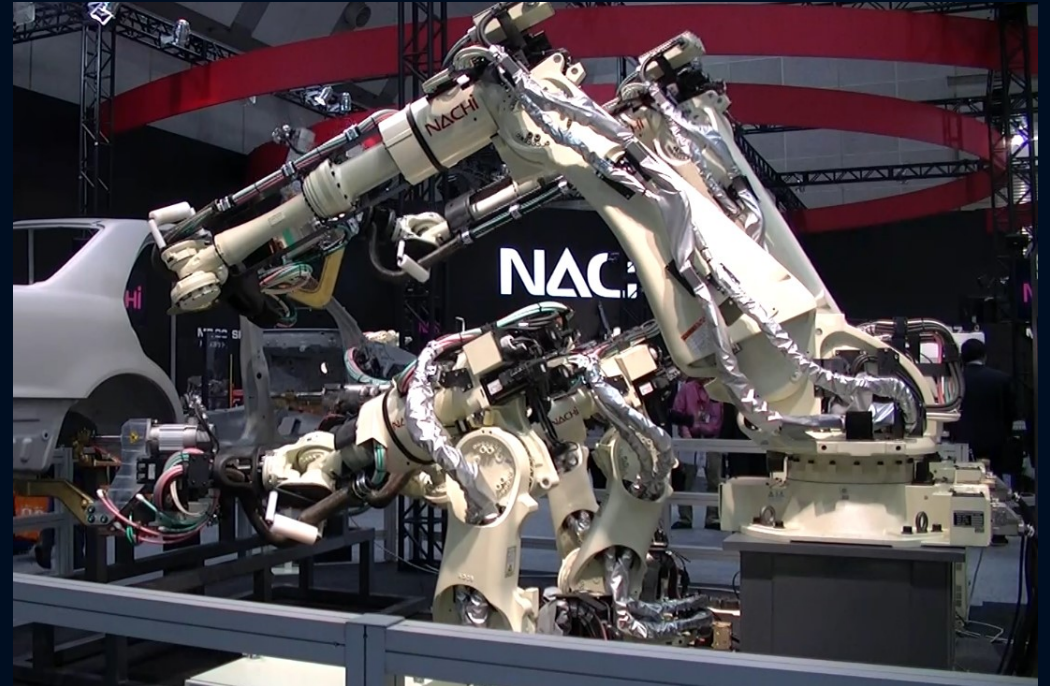

Industrial robot

As a technique to clean the casting skin, the process of shot blasting process and the coating process of paint type agent (medicine used to smoothly remove product from sand mold) are important. Shot blasting balls generally use No. 17 (1.18 - 1.4 mm). Our company uses No. 14 (1.0 - 1.18 mm), it attaches more detailed balls, and the surface is beautiful. Even when spreading the coating agent on the sand mold, careful work is thoroughly carried out so that no dripping will remain.



Leader Company

SV VALLEY is a leader company with "SHIRAKAWA Sokeizai VALLEY"

With Shirakawa City in the Fukushima Prefecture at the helm, multiple Sokeizai industries have come together to form this group. By using techniques such as casting, forging, die casting and more to create materials, and locally processing them including heat treatment, we will provide a stable feed of products for Japan and all over the world. By the use of our knowledge and technology, we intended to contribute to the further development of the industry in Fukushima.

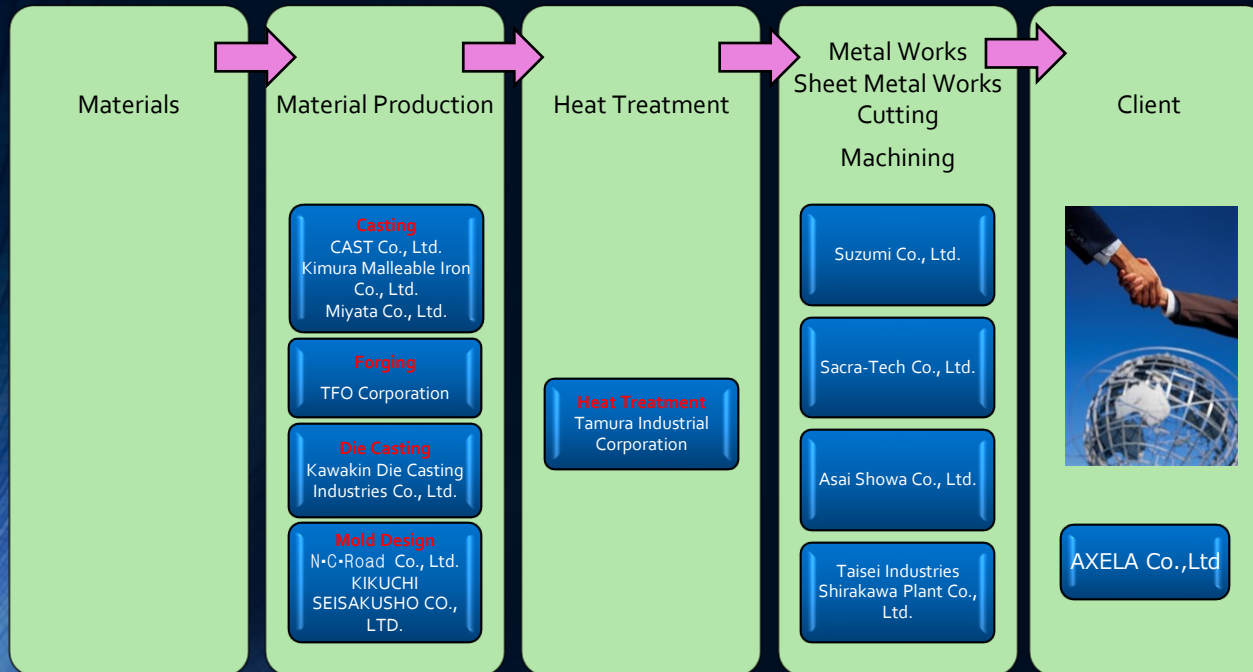

見せましょう
東北の技術力を

SV SHIRAKAWA
Sokeizai VALLEY
www.shirakawa-valley.com

白河素形材ヴァレー

www.shirakawa-valley.com

SV SHIRAKAWA Sokeizai VALLEY

CASTING 

FORGING 

DIE CASTING 

HEAT TREATMENT 

SHEET METAL WORKS 

MACHINING AND CUTTING 

METAL PRESSES 

ONE STOP SERVICE



www.shirakawa-valley.com

CAOT

MIYATA CO.,LTD

TFE ティエフオー株式会社

木村可隆株式会社

TAMURA KOGYO K.K.

沢井シオーワ株式会社

SACRA-TECH

Taisei

SUZUMI

ONE STOP SERVICE
www.shirakawa-valley.com

ENOT is a leader company with THE LEADING JAPAN FOUNDRIES

www.japan-foundries.com



Giving Innovation to the world,

THE LEADING JAPAN FOUNDRIES

www.japan-foundries.com

Giving Innovations to the world,

THE LEADING JAPAN FOUNDRIES

www.japan-foundries.com

Japanese foundries have excellent casting technology and produce high-quality castings in the world. Especially "THE LEADING JAPAN FOUNDRIES" is composed of **33 companies** that possess advanced technologies and is a cutting-edge group to expand the sales network aggressively aiming at the global market.

We are comprised of professionals of the top-level in the casting industry and able to supply stably high-quality castings. And they give all customers quick and efficient responses on estimates, orders and any other correspondence. We are well-experienced in the international business with global manufacturers.

GIFA DÜSSELDORF/GERMANY 16-20 JUNE 2015

GIFA

13. INTERNATIONALE GIEßEREI-FACHMISSE MIT TECHNICAL FORUM
13TH INTERNATIONAL FOUNDRY TRADE FAIR WITH TECHNICAL FORUM

The Bright World of Metals

GIFA 25-29 JUNE DÜSSELDORF GERMANY 2019

GIFA

14TH INTERNATIONAL FOUNDRY TRADE FAIR WITH TECHNICAL FORUM

The Bright World of Metals